

1. LAY OUT THE PANEL LOCATON ON THE WALL

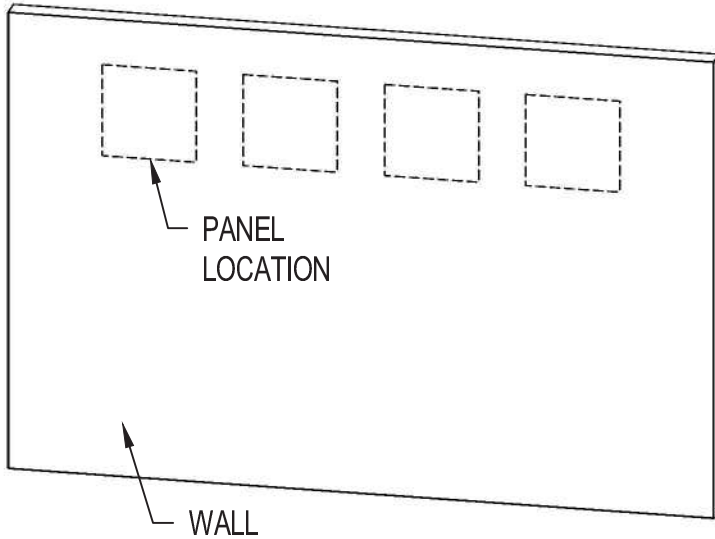

2. SECURE IMPALING CLIPS TO WALL USING APPROPRIATE FASTENERS. CLIPS SHOULD BE LOCATED TO ENSURE THERE IS NO CONTACT BETWEEN CLIPS & FABRIC.

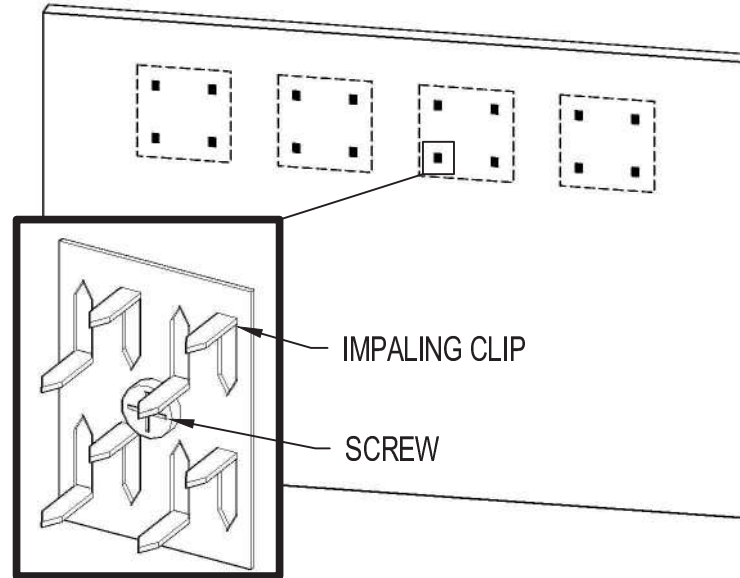

3. APPLY CONSTRUCTION ADHESIVE (BY OTHERS) TO FABRIC PERIMETER ON PANEL BACK. ADHESIVE BEAD SHOULD BE 3/4" x 3/4" x 6" LONG, NO MORE THAN 18" APART.

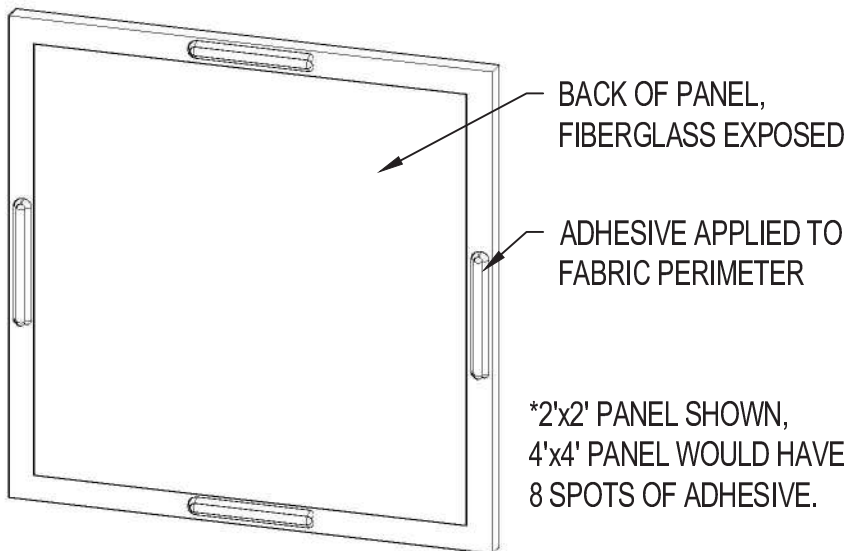

4. ENSURE PANEL IS LOCATED PROPERLY, PRESS PANEL FIRMLY TO WALL. (MAKE SURE THE FIBERGLASS CORE IS BEING IMPALED BY THE CLIPS, NOT THE FABRIC.)

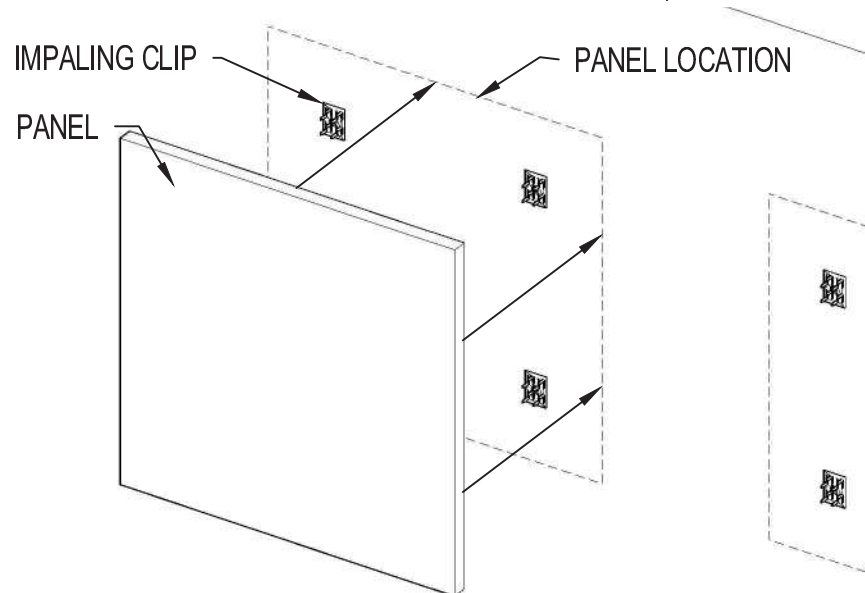

NETWELL NOISE CONTROL



3800 American Blvd W.

Bloomington, MN 55431

WWW.CONTROLNOISE.COM

(800)638-9355

IMPALING CLIP
MOUNTING DETAIL